

011 589 8800

**ECHO**

expert@echo.co.za

®

# HOW WE CUSTOMISE OUR SLAB DESIGN TO SUIT PROJECT REQUIREMENTS

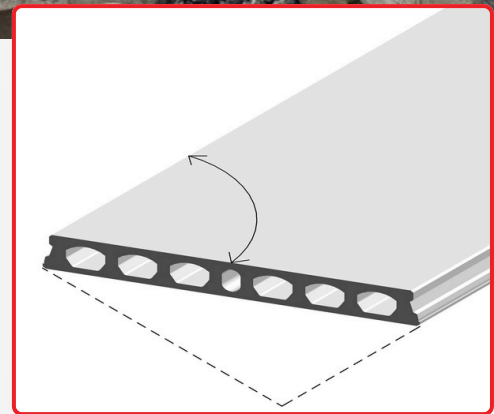
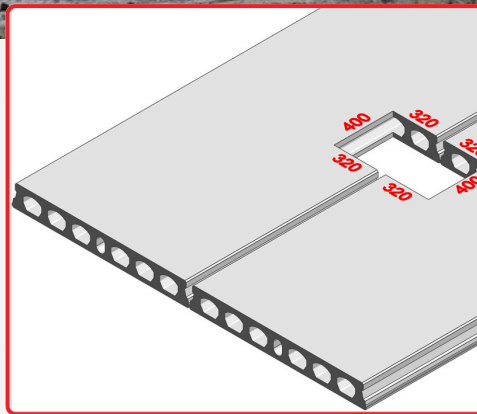
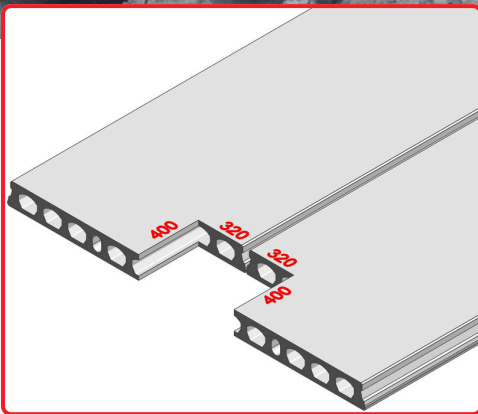

- **Steel hangers** can be used to provide openings for walkways, staircases, skylights, etc.
- **Openings** can be pre-formed in the factory to accommodate services.
- Small openings can be made by **coring** on site.

Does the coring affect the slab strength with cutting through the tendons? No.

As the tendons are embedded in the concrete, they recover their full stress in about 300 mm. NOTE, however, there is a limit to the number of holes that can be made in a single panel.

Do all buildings have to be designed in 1200 mm increments and be rectangular? No.

The panels can be cut to non-standard widths to match on-site dimensions. The panels can be cut in 100 mm increments up to a minimum of 300 mm wide. **Angular cuts** are also possible to fit reservoirs and angular buildings.